

CHROMOFLEX Pro DALI stripe CV

DALI DT8 compatible

- 4-channel controllable via DALI (DT8 compatible)
- Number of channels adjustable
- manual mode with 230 V control possible (only for 1-channel solutions)
- Input voltage: 10-48 V DC (depending on the load used)
- com+ common anode
- 4 controllable channels from monochrome to RGBW/RGBA applications



Please note the installation- and safety instructions.



	66000574
Product	4 channels from monochrome to RGBW/RGBA, DALI DT8 compatible
Number of channels	4
Operating voltage DC	10 V DC-48 V DC
Output current per channel	2,2 A
Max. total power	424 W
Power consumption in standby mode	Psb: max. 0,5 W
Power consumption in network standby mode	Pnet: max. 0,5 W
Power consumption in idle mode	not intended for this
Light source type	suitable for LED
Efficiency at full load	99 %
Strain relief	Yes
max. wire cross-section	2,5 mm ²
Connection via	screw terminals
Color of body	grau/blau
Length	182 mm
Width	52 mm
Height	22 mm
Weight	99 gr
Remarks	max. power: 212 W at 24 V / 424 W at 48 V com+ common anode

When using a KNX/DALI gateway, we recommend carrying out preliminary compatibility tests.

CONNECTION SCHEME

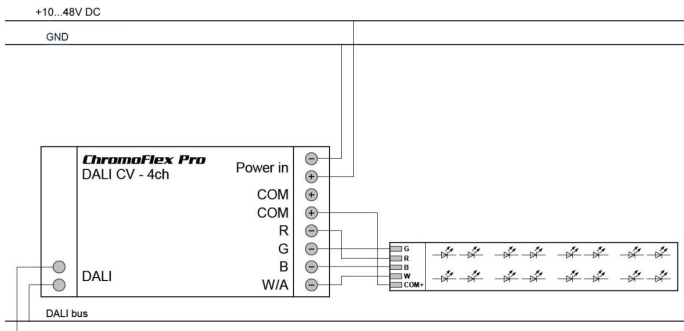

The guarantee period for the product is 5 years and begins on the day of shipment. Reference is the date of the delivery bill. The guarantee period may differ for accessories.

RECOMMENDATION FOR DISPOSAL

Please help to avoid waste. Should you ever wish to part with this item, please remember that many of its components are made of valuable raw materials and can be recycled. Therefore, please do not dispose of it in the dustbin, but please take it to your collection point for electrical appliances. Thank you for your cooperation!

