

CHROMOFLEX Pro KNX stripe CV 4-channel

- number of channels is configurable via ETS; compatibility from ETS4
- optimised settings, especially for „tunable white“ applications
- input voltage: 10-48 V DC (depending on the load)
- com+ common anode
- short-circuit-proof
- 4 controllable channels from monochrome to RGBW/RGBA
- CHROMOFLEX KNX libraries freely available on www.barthelme.de



Please note the installation- and safety instructions.



	66000374
Product	4 channel for RGBW/RGBA applications, KNX control
Number of channels	4
Operating voltage DC	10 V DC~48 V DC
Output current per channel	2,2 A
Max. total power	424 W
Power consumption in standby mode	Psb: max. 0,5 W
Power consumption in network standby mode	Pnet: max. 0,5 W
Power consumption in idle mode	not intended for this
Light source type	suitable for LED
Efficiency at full load	99 %
Strain relief	Yes
Connection via	screw terminals
Color of body	grau/blau
Length	182 mm
Width	52 mm
Height	22 mm
Weight	93,6 gr
Remarks	com+ common anode

CONNECTION SCHEME

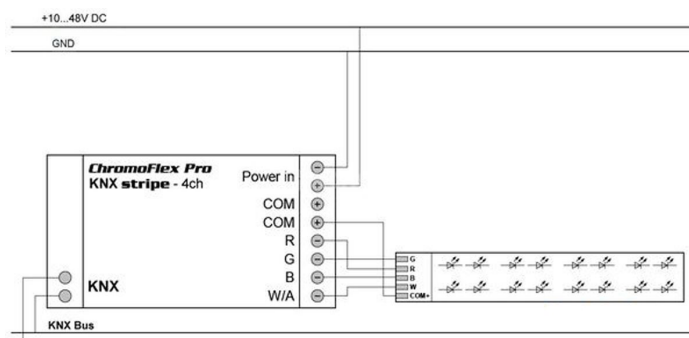

The guarantee period for the product is 5 years and begins on the day of shipment. Reference is the date of the delivery bill. The guarantee period may differ for accessories.

RECOMMENDATION FOR DISPOSAL

Please help to avoid waste. Should you ever wish to part with this item, please remember that many of its components are made of valuable raw materials and can be recycled. Therefore, please do not dispose of it in the dustbin, but please take it to your collection point for electrical appliances. Thank you for your cooperation!

